

PowerRail 303

OPERATING INSTRUCTIONS

March 2003

© Northern Design (Electronics) Ltd Bradford UK

1 Safety

This instruction sheet gives details of safe installation and operation of the *PowerRail 303* electricity meter. Safety may be impaired if the instructions are not followed. Labels on each meter give details of equipment ratings for safe operation. Take time to examine all labels before commencing installation. Safety symbols on the meter have specific meanings.



Caution

Refer to Operating Guide

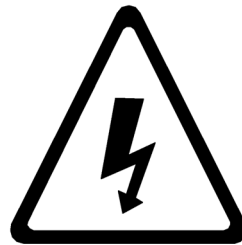

Warning

Risk of electric shock

2 Mounting the Unit

The *PowerRail 303* enclosure conforms to DIN 43880, 6 Modules wide. The unit is therefore compatible with a number of standard DIN distribution systems with 45mm cut-outs. The *PowerRail 303* should be mounted on a 35mm, symmetric DIN rail of minimum length 106mm.

3 Current Inputs

Recommended external CTs should conform to Class 1 per IEC 60044-1. The secondary of the CT should be specified to suit the input rating defined on the meter label (5A as standard). Cables used for the current circuit should have a maximum conductor size of 4.0mm² and should be kept as short as possible to reduce cable losses loading the CT secondary.

WARNING

NEVER allow the secondary of a current transformer to become open circuit while a primary current flows. Under these conditions dangerous voltages may be produced at the secondary terminals.

4 Voltage Inputs

Cables used for the voltage measurement circuit should have minimum ratings of 600V, 250mA AC. The maximum conductor size is 4.0mm². External protection fuses are recommended for the voltage measurement inputs. These should be rated at 160mA max, Type F, with a voltage rating to suit the maximum inputs to the meter.

5 Auxiliary Mains Supply (L & N)

The **PowerRail 303** is supplied from an auxiliary mains input, isolated from the voltage measurement inputs. This may be connected separately or in parallel with the measurement inputs. Ensure the ratings detailed on the instrument label are not exceeded.

Separate connection of the auxiliary mains is advantageous when:

- Measurement voltages are expected to vary over a wide range
- Measurement voltages are unsuitable for meter supply
- Voltage inputs are taken from low power PT secondaries.

NOTE: The auxiliary mains supply must be externally fused. An anti-surge (Type T) fuse should be used, rated 230V with a rupture current of 100mA.

6 Pulse Output (optional)

An isolated pulse output may optionally be provided on the **PowerRail 303**. The pulse output provides a volt free contact pair closure for a programmable number of increments (1, 10, 100 or 1000) of the energy display. (e.g. 1 pulse per 10 kWh). The signal provided is designed to interface to building management systems, data collectors, remote counters etc.

On completion of the programmed number of counts the Pulse Output terminals (Figure 1 to Figure 4) momentarily appear short circuit (100ms). At all other times the pins appear open circuit.

The Pulse Output terminals are isolated (@ 2.5kV) from all other parts of the instrument providing safe connection to external systems.

Each pulse output is indicated on the front panel of the **PowerRail 303** by a single flash of the **Pulse** LED.

7 Meter Connections

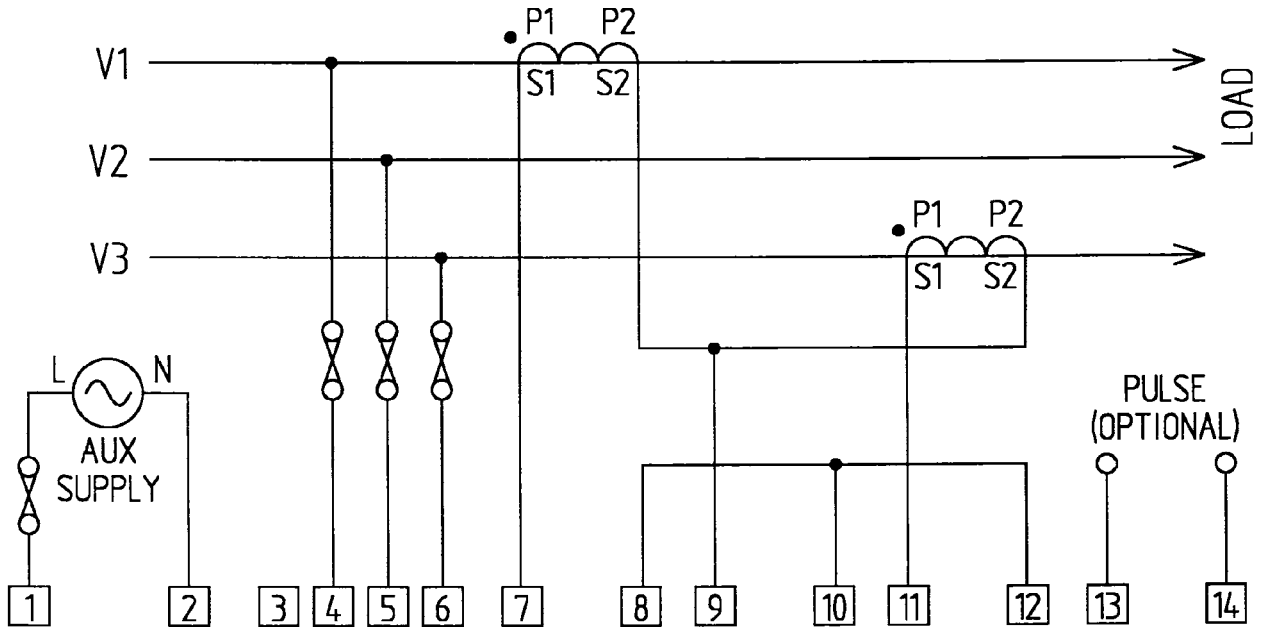

Figure 1 3-Phase 3-Wire (2CTs)

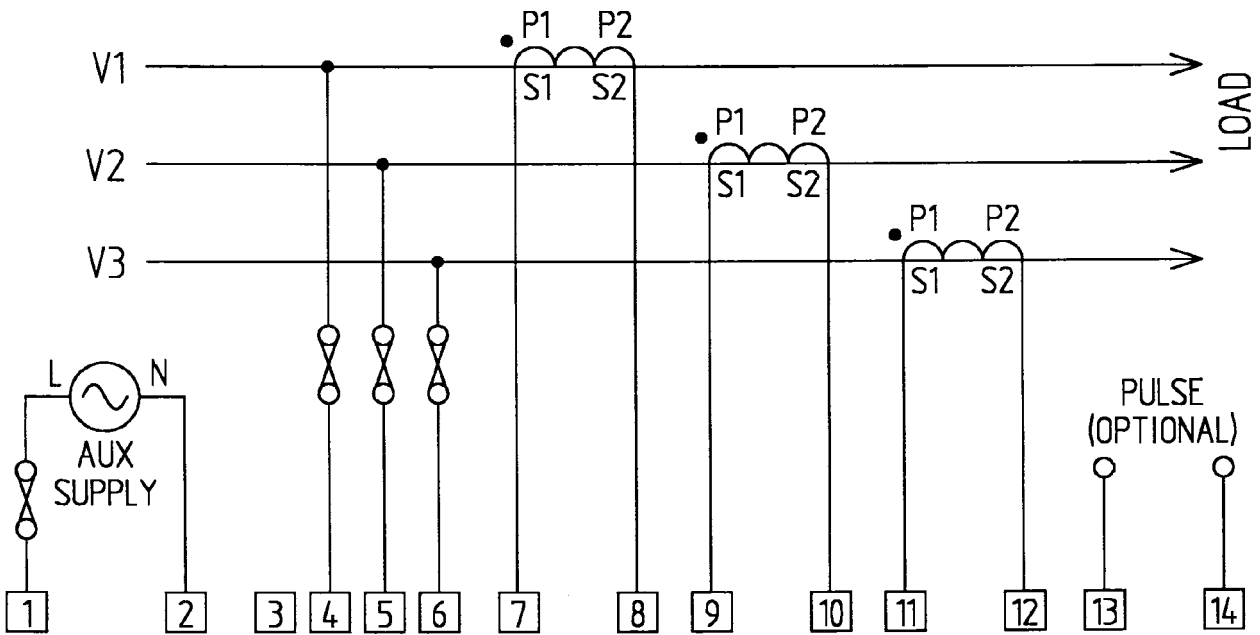

Figure 2 3-Phase 3-Wire (3CTs)

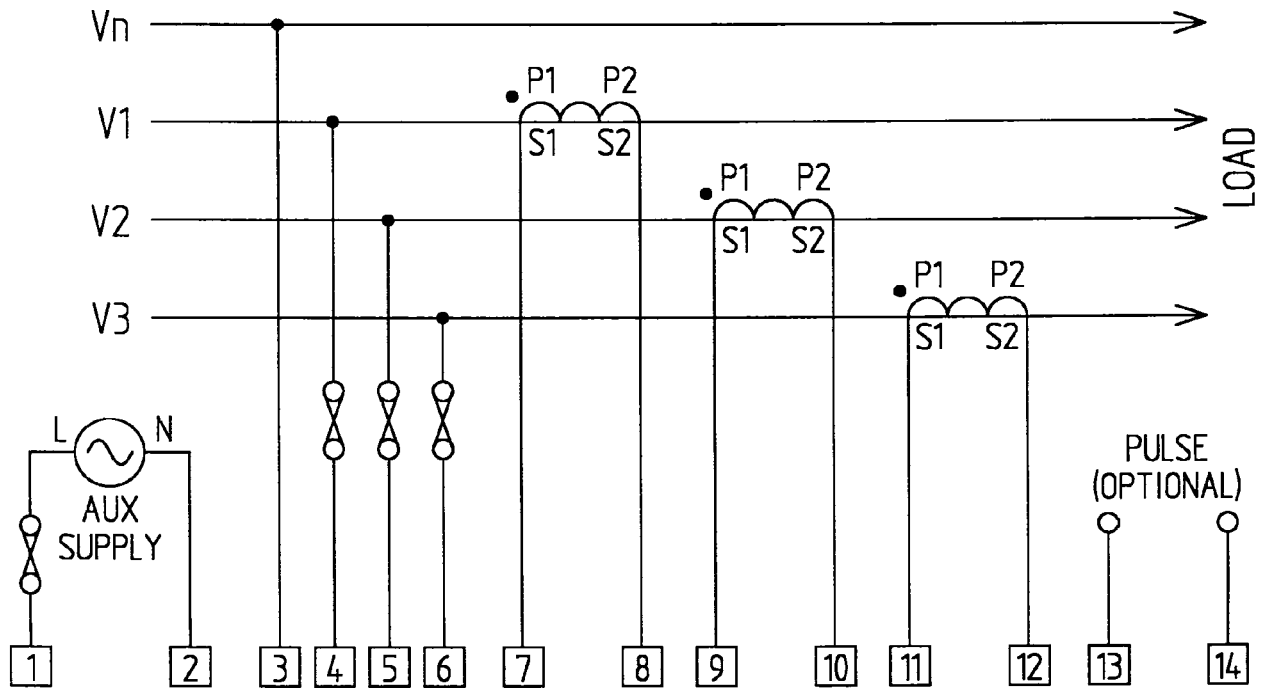

Figure 3 3-Phase 4-Wire

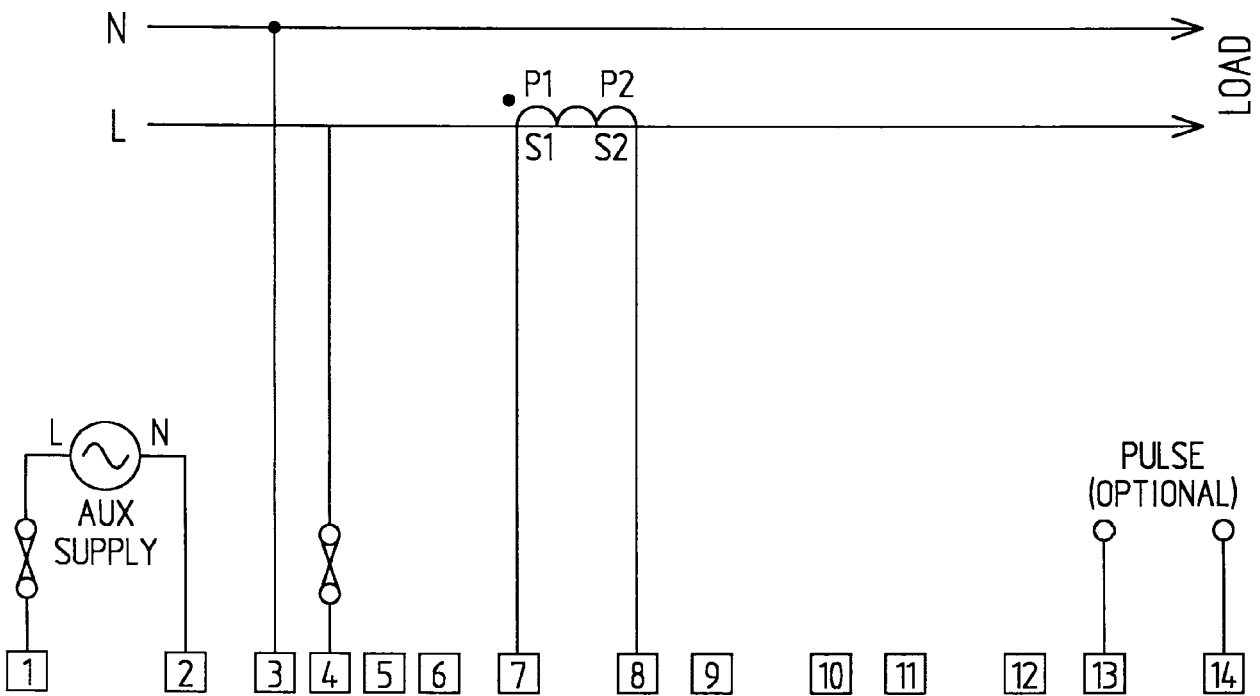

Figure 4 Single Phase

8 Operation

The **PowerRail 303** front display panel is shown below. Three keys labelled **ND**, **E** and **P** allow the user to access all functions of the meter.



Figure 5 Front Panel

8.1 Total kWh Register

This default display presented on power up shows total kWh on an 8-digit accumulating register. Register scaling is determined by user programmed CT and/or PT constants. On standard **PowerRail** meters this register may not be reset.

8.2 kWh Count Register

The kWh Count display is a 7-digit resetable accumulating energy register. This acts in a similar manner to the “Trip” display on a vehicle odometer.

- Press the **E** key to select Total kWh or kWh Count display pages. The kWh Count display remains visible for 1 minute before the unit reverts to Total kWh mode.
- Press and hold the **ND** and **E** keys for approximately 7 seconds to reset the kWh Count register to zero.

8.3 kW Display

A display of instantaneous kW is available by pressing the **P** key. This display remains visible for 1 minute before the unit reverts to Total kWh mode. The kWh key may be used to return to kWh mode before the minute has elapsed.

8.4 Reverse Connections

If the **PowerRail 303** detects negative power at its input terminals the ‘**REV CT**’ message is displayed and the kWh register is frozen.

This condition is most commonly caused by wiring errors. The most common of these errors is incorrect orientation of CT primaries (P1/P2) or secondaries (S1/S2).

9 Meter Constants

The PowerRail 303 displays are scaled to take account of external current and/or voltage transformers. Two scaling factors **CT** and **SCAL** are provided for convenience. These are multiplied together to provide a single constant for the meter. Values of CT range from 10 to 2000 in steps of 10. SCAL may be set as 0.1, 1, 10, 100 or 1000.

9.1 CTs Only Fitted

In systems with no voltage transformers the **CT** constant should be equal to the **primary** rating of the CTs connected. The **SCAL** constant would normally be set to 1.0.

If non-standard CTs are fitted it is possible to combine the two constants (**CT x SCAL**) to achieve the desired result. For example if 25A CTs are used select **CT=250** and **SCAL=0.1**.

9.2 CTs and VTs Fitted

When current and voltage transformers are used **CT** and **SCAL** may be combined to provide a single constant as:

$$\mathbf{CT \times SCAL = CT \text{ Primary} \times PT \text{ Primary} / PT \text{ Secondary}}$$

For example if 500A CTs and 11000/110V VTs are used select **CT=500** and **SCAL=100**

9.3 Display Scaling

Display legends and a decimal point provide optimum resolution for any load as:

Nominal kW	Resolution	
< 2,88 kW	1 Wh	0.1 W
< 28,80 kW	0.01 kWh	0.001 kW
< 288,00 kW	0.1 kWh	0.01 kW
< 2,88 MW	1 kWh	0.1 kW
< 28.8 MW	0.01 MWh	0.001 MW
< 288 MW	0.1 MWh	0.01 MW
<2880 MW	1 MWh	0.1 MW

Where: **Nominal kW = 3 x Vnom x CT x SCAL**

Vnom is the nominal phase voltage measurement rating of the *PowerRail 303* detailed on the meter-rating label.

10 Programming

To enter programming mode Press the **ND** key and **hold** for 5 seconds. The unit shows the CT Primary Setup screen.

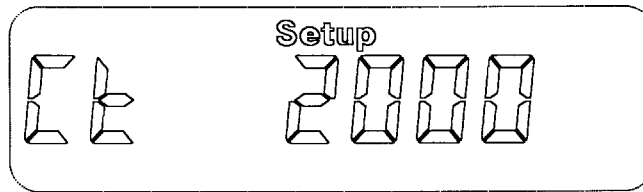

The CT primary rating may be adjusted in 10A steps by pressing the Δ or ∇ keys until the desired current is displayed. Press **ND** when the selection is complete.

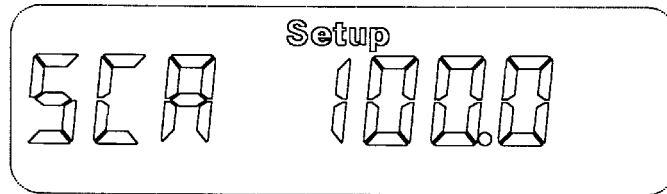

Press the Δ or ∇ keys until the desired Scaling Factor is displayed. Press **ND** when the selection is complete.

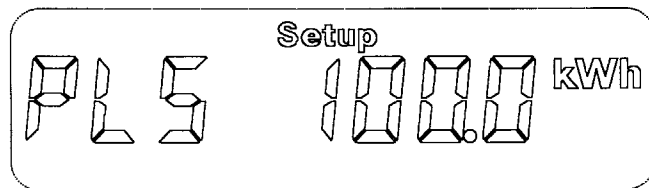

Pulse output is optional on the **PowerRail 303**. If no pulse output is fitted this setting has no effect on meter operation.

Pulse output rate may be set to provide 1 pulse after each 1, 10, 100 or 1000 increments of the LCD register. Press the Δ or ∇ keys until the desired Pulse Rate is displayed. Press **ND** when the selection is complete.

11 SPECIFICATION

AUX MAINS	Nominal 230V, $\pm 15\%$, 45-65Hz Optional 110V Other voltages available to special order Burden 4W max
VOLTAGE	Nominal $U_n = 400V$ L-L, 230V L-N Optional $U_n = 110V$ L-L, 63.5V L-N Other voltages to special order AC 45-65Hz fundamental Range = $U_n \pm 20\%$ Burden 0.1W per phase Overload 2 x U_n for 2 Seconds
CURRENT	Nominal $I_b = 5A$ rms Optional $I_b = 1A$ rms Range = 0.005 I_b to 1.2 I_b Burden 0.1VA per phase. Overload 40 x I_b for 1 Sec
DISPLAY	Liquid Crystal (LCD). 8 x 9mm Digits + Legends Backlight green LED Memory 10 Years in the event of power fail.
PULSE	Normally Open Volt Free Contacts. Contact Rating 50V, 150mA, 5VA AC/DC. 100mS Closure per display increment. Optional 500mS Closure T Switching Time (t_r , t_f) 2mS max Contact Bounce 0.5mS max.
ACCURACY	EN 61036 Class 1 (kWh)
CASE	DIN 43880, 6-Modules wide 106mm x 90mm x 58mm Cut-Out 45mm x 106mm NORYL. ULV94 V-O self extinguishing
DIN RAIL	DIN EN 50022 106mm (min) x 35mm
TERMINALS	Rising Cage 0.25mm ² to 4mm ²
OPERATION	-10°C to 55°C. <75% RH non condensing
STORAGE	-25°C to 70°C. < 85% RH non condensing