

Single Phase BS Credit Meter with Internally Switched 100A Contactor and
2A Relay

5184
Technical data



The 5184 meter is a whole current credit meter with an integral 100 amp contactor and a 2 amp relay.

Technical Specifications

General

Voltage

Nominal Voltage Un	230V
Voltage Range	80-115%Un
Voltage Withstand	415V Continuous

Frequency

Nominal Frequency	50Hz
Frequency Variation	+/- 2%

IEC-Specific Data

Current

Base Current	
Direct Connection Ib	15, 20A
Current Max	
I _{max}	100A

Measurement Accuracy

Measuring Accuracy	IEC 62053-21 Class 1 or 2
--------------------	---------------------------

Measurement Behaviour

Starting Current	
IEC	Class 1 0.4% of Ib Class 2 0.5% of Ib
Max Measuring Range	60mA up to 100A

Approvals

Quality	Manufactured to ISO 9001:1994
OFGEM Approval Number	1003
Certified Life	20 years

General

Operating Behaviour

Voltage Interruptions (Power Down)	
Blocking of inputs and outputs	Immediate
Standby Operation	for 0.15s
Data Storage after	0.15s
Switch Off	after approx 0.15s

Voltage Restoration (Power Up)

Function Standby (depending on duration of failure)	<5s
Detection of energy direction and phase voltage	<5s

Power Supply Quality

The meter complies with EN63052-11 Section 7.1.1 Voltage range and 7.1.2 Voltage dips and short interruptions

Power Consumption

Voltage Circuit	<5W <25VA
Current Circuit	<4VA

Environmental Influences

Temperature Test	IEC62053-21
------------------	-------------

Temperature Range

Operation	-10°C to +45°C
Power Measurement Range	-25°C to +55°C
Storage	-25°C to +70°C
This complies with EN 62052-11:2003 section 6.1	

Temperature Coefficient **

Range	From -10°C to +45°C
Typical mean value	±0.015% per K
cosφ =1 (from 0.1 Ib to I _{max})	±0.05% per K
cosφ=0.5 (from 0.2 Ib to I _{max})	±0.07% per K
Impermeability to IEC 60529	IP51

Shock Test

BS EN60068-2-27

Electromagnetic Compatibility

Electrostatic Discharges	to IEC 610000-4-2
Contact Discharges	8kV
Air Discharges	15kV
Electromagnetic RF Fields	to IEC 610000-4-3
80 MHz to 2 GHz	at least 10V/m
Radio Interference suppression	to IEC/CISPR 22 Class B

Fast Transient Burst Test

to IEC 610000-4-4

With basic current Ib:	
For current and voltage circuits	4kV
For auxiliary circuits >40V	4kV
With open current circuit	
for voltage and current circuits	4kV

Fast Transient Surge Test

to IEC 610000-4-5

Impulse Voltage	4kV
Impedance of source	2Ω
Rise/Decay time of impulse voltage	1.2μs/50μs
Rise/Decay time of impulse voltage	8μs/50μs

Insulation Strength

Insulation Strength	4.4kV at 50Hz for 80 seconds
Impulse Voltage Strength	to IEC62053-11
Impulse Voltage	6kV
Impedance of source	500Ω
Rise/Decay time of impulse voltage	1.2μs/50μs

Protection Class II to IEC626050-131



Display

Characteristics

Type	7 character, 7 segment LCD
Digit size	8x3.5mm
Number of Digits	6 significant numbers 2dp

Communication Interfaces**

Optical Interface

Type	serial, bi-directional interface
Protocol	IEC 62056-21

Case Material

Base, Top Cover and Terminal Cover
Flame retardant and UV stabilised polycarbonate

Weight and Dimensions

Weight

Standard	800g
----------	------

Dimensions

Width	150mm
Height	170mm
Depth	56mm

Terminal Details

Arrangement	BS5685
Size	8.3mm diameter

Connections

Standard Layout and Dimensions

Dimensions

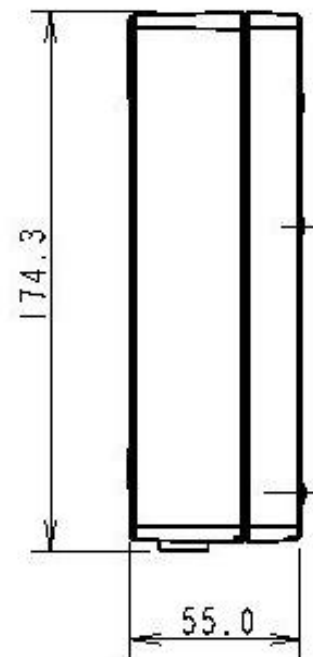
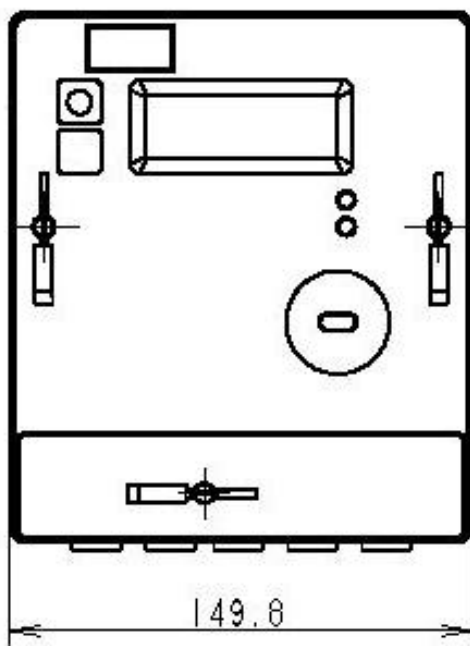

Terminal Connection Diagrams

